

## MC-45



Since the maximum air volume is 42m<sup>3</sup> / min, it can be used for multiple suction points. The two-stage collection structure by a special filter is used. Ideal for collection oil mist of grinding machines, lathes machine, surface grinding machines, double-headed grinders machine, cleaning work, and air blowing work with an air gun.



Filter Type



Water soluble mist / Oil  
mist



Max. airflow



Premium efficiency  
motor

### MEDIUM AIRFLOW MIST COLLECTOR

- Good for multiple suction.
- With two special filter (metal mesh + urethane sponge) to capture mist.
- Low noise level.



MC-45 provide Exceptional cleaning capacity with 5 stage filter such as 2 set of Rectification Plate, Eliminator, Metal mesh Primary filter, Urethane foam Secondary filter.

Low level noise

65 ± 2 dB [A] or less Low level noise design that does not disturb the work. It realizes both high-volume suction and quietness.



The collected water-soluble cutting oil can be continuously discharged by connecting a hose from the discharge tank at the bottom of the main body. It can be collected and reused without the hassle of the operator.

## Equipment Layout

### Centralize Layout

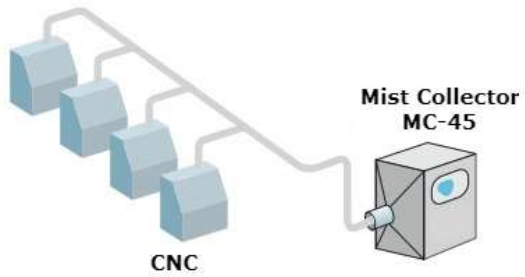

## Equipment Layout

### Individual Layout



## INTERNAL STRUCTURE

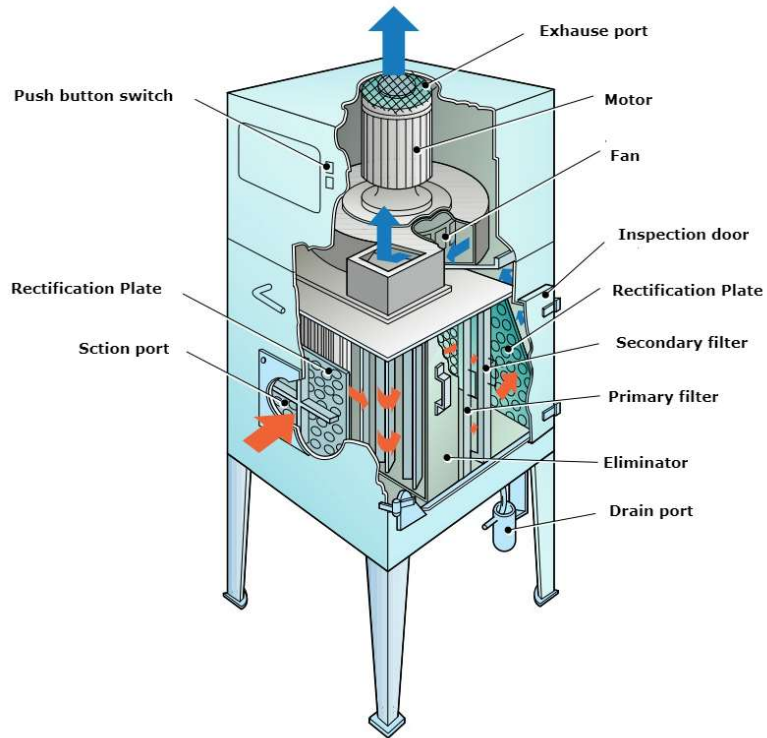

## EXTERNAL VIEW

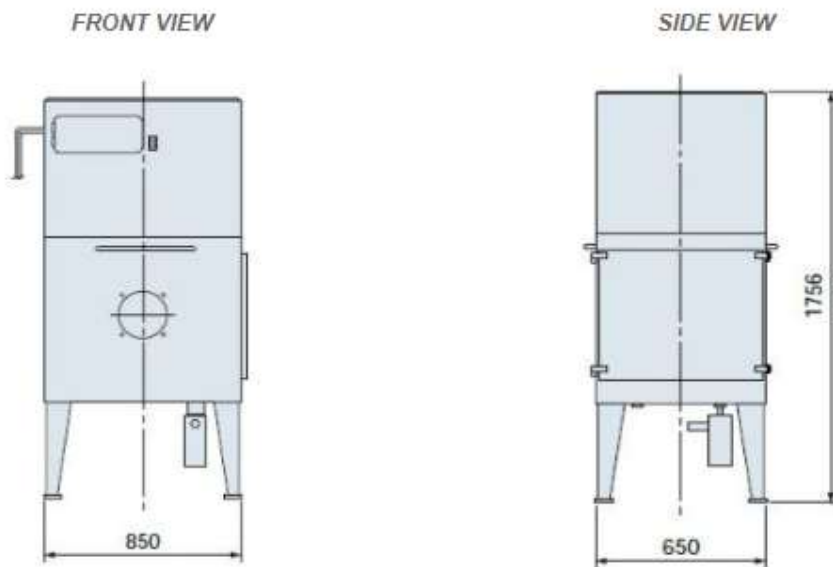

## SPECIFICATION

Particular	Unit	MC-45
Power Supply	Volt	220
Frequency	Hz	60
Phase		3P
Output	kw/hp	2.2/3.0
Max Airflow	m <sup>3</sup> /min	42
Max. Static Pressure	kPa	2.75
Suction Port Ø	mm	200.0
Dimension (W x H)	mm	850x650x1759
Weight	kg	185